

Designers' guide to firefighting operations

Emergency vehicle access

F5-02 GD



Document Title: Emergency vehicle access

Published: July 2025

Document review date: July 2028

Status of this document

This document is issued by Fire and Emergency New Zealand.

Recommendations for change

The document, its content and specific processes are not to be altered except through Fire and Emergency New Zealand document management processes.

Requests or recommendations for changes to this material should be sent to National Manager Response Capability.

© July 2025 Fire and Emergency New Zealand

Table of contents

1.	Context	1
2.	Definitions	1
3.	Our operations.....	4
4.	Challenges.....	4
4.1.	Fire and Emergency vehicles	4
4.2.	Access requirements	5
4.3.	Vehicle weights (loads).....	10
4.4.	Site access and security features.....	12
4.5.	Vehicle hard-standing.....	13
5.	Recommendations.....	15
5.1.	Completing the firefighting facilities checklist	15
6.	Related information.....	16
6.1.	Designers' guide to firefighting operations.....	16
6.2.	Legislation.....	16
6.3.	Standards.....	16
6.4.	References.....	16
	Appendix A – Images	18
	Appendix B – Site layout examples	20

1. Context

Scope	We need to be able to reach your building with our different vehicles in a fire or other emergency. This chapter helps you understand the types of vehicles we use, and how you can provide access for them on your site.
Who this chapter is for	<p>This chapter outlines our position on appropriate considerations for building owners, building designers and other building practitioners, on emergency vehicle access to sites, both completed and under construction/refurbishment.</p> <p>It may also provide useful guidance for anyone undertaking planning of any kind that needs to consider emergency vehicle access.</p>
What is not included in this chapter	<p>This chapter is a guide to provide advice to the building industry on Fire and Emergency's operations and recommendations in relation to emergency vehicle access – it does not replace any mandatory/statutory requirements.</p> <p>We recommend you read it alongside other chapters in the guide. This is not an exhaustive guide to Fire and Emergency operations, but an overview of the relevant expectations building industry stakeholders can have of our operations.</p>
Legislative framework	<p>We aim to reduce the risk to both firefighters and building occupants through encouraging appropriate building design which allows us to achieve our statutory objective (under the Fire and Emergency New Zealand Act 2017) to reduce the incidence of unwanted fire and the associated risk to life and property. Our functions include responding to and suppressing fires and attending to other types of emergencies that may occur in a building.</p> <p>Read this guide alongside the:</p> <ul style="list-style-type: none"> • mandatory requirements of the New Zealand Building Code (Building Code) • requirements of New Zealand Standards (Standards), and • Building Act 2004. <p>This guide does not replace any part of the Building Code or Standards or other mandatory building requirements.</p> <p>We note that the Building Code Fire Safety C – Protection from fire clauses C1– C6 define the Building Code performance requirements of the Building Act 2004. Clause C5 is the performance requirement on 'Access and Safety for Firefighting Operations'.</p>

2. Definitions

The following definitions apply for the purposes of this chapter. Defined terms used throughout this document are consistent with the Building Act 2004, Building Code and Acceptable Solutions C/AS2.

Address point	This point is part of the data set administered by Toitū Te Whenua Land Information New Zealand (LINZ). It is the address (point) where the building is, or will be, located. The address point can be either a singular or a range of individual points as described on the LINZ data set.
Aerial device	Encompasses all the types of Fire and Emergency aerial components (turntable ladder, elevating platforms, elevating monitors, baskets, cages and booms).

Aerial vehicle	A specialised emergency vehicle that has an aerial device that hydraulically rises to suppress fire and/or effect rescue as well as support other operations.
Allowable bearing pressure	The calculated pressure required to counter compression forces exerted by dead loads (i.e. the minimum strength required to maintain stability under a weight load).
Appliance	An emergency vehicle that provides capability to Fire and Emergency's mandated functions.
Attendance point	<p>The hardstanding area where the first attending Fire and Emergency vehicle will stop and set up. There is usually only one attendance point located at the building's primary entry point.</p> <p>The attendance point should comply with clause 6.2.1 of C/AS2, and must comply with Clause C5.3 of the Building Code. This will give access to within 20m of:</p> <ul style="list-style-type: none"> ○ indications of fire location ○ controls for fire safety systems ○ inlets for fire sprinkler or hydrant systems. <p>The attendance point is the initial tasking and safety briefing point for crews before they deploy to any other access point. It must have facilities that give firefighters clear information, in compliance with Building Code C5.7.</p> <p>For unusually large or complicated building layouts, a second (or more) attendance point may be appropriate. This must be discussed and agreed with Fire and Emergency Operations.</p> <p>For a full description of the attendance point, refer to F5-02 GD FFO Emergency vehicle access.</p>
Breathing apparatus (BA)	A device firefighters wear to provide breathable air in an atmosphere that is immediately dangerous to life or health. Also known as self-contained breathing apparatus (SCBA) or compressed air breathing apparatus (CABA).
Building hydrant system	Fixed water main pipe system, normally already charged with water and supplemented by Fire and Emergency pumps. This should not be confused with an in-ground hydrant connected to the town mains.
Canopy	Projecting hood supported on brackets, corbels or columns over a door, window or niche.
Carriageway	The driveable portion of a road (which may or may not include a sealed top surface layer).
Collapse zone	<p>The collapse zone is an area around the building measured as 1.5 times the height of the structure. This is the area which would be considered dangerous in the event of an outward failure of a facade element.</p> <p>In this document, the term 'collapse zone' only applies to pre-cast concrete panel (tilt-slab) and unreinforced masonry type construction.</p> <p>Use a pragmatic approach where practicable when designing, and when in doubt, consult Fire and Emergency.</p>

Fire engineering brief (FEB)	A formal process outlined in the International Fire Engineering Guidelines for all stakeholders to define and agree on the basis and scope of work for fire engineering analysis.
Firefighter access point	<p>The place where firefighters gain access to a building. This must comply with the New Zealand Building Code Clause C5.6:</p> <p>Buildings must be designed and constructed in a manner that will allow firefighters, taking into account the firefighters' personal protective equipment and standard training, to:</p> <ul style="list-style-type: none">(a) reach the floor of fire origin,(b) search the general area of fire origin, and(c) protect their means of egress.
Fire and Emergency vehicular access	<p>Vehicular access provided to Fire and Emergency vehicles should be consistent with Acceptable Solution C/AS2 Part 6 (relating to firefighting).</p> <p>Buildings must be provided with access that allows appliances to reach a position that makes it convenient for firefighters to get into the building and access the inlets to fire sprinkler systems or building fire hydrant systems, where these are installed.</p> <p>Occupants of risk group SI are more likely to require rescue by Fire and Emergency. An additional recommendation for this risk group is to allow access for the larger size of aerial vehicles to get as close to buildings as possible with space to 'jack' the vehicle.</p> <p>If a building has a large footprint (which is most likely to occur for a single-storey building such as a warehouse) and is not protected with fire sprinkler systems, access to two sides of the building is required. This gives Fire and Emergency the ability to access the building in a number of places and means that their travel within the building is minimised to reach any fire source.</p> <p>In addition, for the health and safety of our personnel, this access:</p> <ul style="list-style-type: none">• should not involve a canopy, or other part of a structure to drive or park under• should be located outside a horizontal collapse zone requirement of 1.5 times the height of a portal frame building• should be within 135 metres of a firefighting water supply. <p>Where access meets these recommendations above, and is acceptable to Fire and Emergency, the 75 m hose run may be measured from this hard-standing point.</p>
Hard-standing area (for Fire and Emergency vehicles)	<p>A hard (roading) surface capable of withstanding the fully laden weight of a fire appliance from which fire operations for a structure are conducted. A hardstanding must be big enough for the fire appliance to enter, exit and manoeuvre and for firefighters to move around it to connect hose and safely access equipment. In most cases, the hardstanding will be the main road if the structure is close to it.</p> <p>To be operationally useful, hardstanding must be within 135 metres of a firefighting water supply.</p> <p>Additionally, for the health and safety of our personnel, hardstanding areas:</p> <ul style="list-style-type: none">• must not be located under a canopy, or other part of the structure on fire.• must not be located close to significant hazards such as dangerous goods, gas cylinders or similar.

- must have a path of retreat for the appliance and crew if the incident deteriorates.
- must be located outside the hazard zone of the firecell on fire. This hazard zone will include consideration of the following:
 - a horizontal collapse zone requirement of 1.5 times the height of external walls of the firecell on fire
 - radiant heat from flame projection or external walls exposing the pump operator and appliance
 - the impact of the fire safety features within the building (for example, sprinklers).

Jacks

External outriggers and jacks fitted to aerial vehicles that extend to stabilise the vehicle when its centre of gravity shifts during the operation of the aerial device.

Overhang

The portion of a vehicle's body that extends forwards past the front wheels or backwards past the rear wheels. It relates to body swing, which is where a set of wheels when turning acts as a pivot point and the bodywork swings past that point. The longer the overhang, the greater the body swing.

3. Our operations

Vehicle types

We use several different types of vehicles (also referred to as appliances).

Each type of vehicle carries a different combination of equipment and has a specific function at an emergency incident. Most of our vehicles have a specially built body fitted on a commercial vehicle chassis, normally a truck.

Vehicle types include pumping appliances, aerial appliances and a range of specialist function vehicles such as mobile command units, logistics and support vehicles, and water tankers.

Timeliness

To fight a fire effectively, save lives and limit damage to property, we need to respond quickly and start applying water while the fire is still small. While automatic detection systems and good information help us respond quickly, good access is also vital.

This highlights the importance of having designated hard-standings with all the provisions for a fast fire attack proximate to as many parts of a building as possible, that are free from obstructions.

4. Challenges

4.1. Fire and Emergency vehicles

Capability of vehicles

Pumping appliances are vehicles used to pump water for firefighting. They carry a relatively small amount of water (1,350–2,000 litres) and a limited length of hose. This is why we must have access to a water supply and must also be able to base our operations near the building, so firefighters can reach the fire with water. Often, this can be done from the public road, and this is how we prefer to operate where possible. However, for large sites, sites with multiple buildings, or sites with large set-backs, our vehicles may have to operate from within your site, which is less favoured.

Aerial appliances are larger and heavier than our other vehicles and may be on a two-, three, or even four-axle heavy vehicle chassis. Aerial appliances have limited reach and need to get close to buildings or structures to operate effectively. We will normally try to reverse these vehicles into position beside a building and, where possible, operate from building corners.

For these reasons, we recommend that you provide access and working space for Fire and Emergency vehicles on your site.

Vehicle dimensions

Each vehicle type has different dimensions. Table 1 below shows maximum vehicle dimensions of Fire and Emergency's current fleet of vehicles.

Table 1 – Maximum parameters for Fire and Emergency vehicles

Dimension	Maximum dimensions
Gross vehicle mass	25 t
Maximum overall length	12.6 m
Maximum overall width	2.55 m (6.5 m when stabilisers are deployed)
Required free height	4 m

4.2. Access requirements

Carriageway widths

Carriageways should be wide enough to allow our vehicles to get through them easily and to allow us to carry out emergency operations. This means that when our vehicle is parked, we can easily open and exit the doors, access equipment from its compartments and safely connect the hose to the pump.



Figure 1 – A pumping appliance showing width required for hose

To accommodate a Fire and Emergency vehicle, carriageways should have a minimum width of 4 m. This can be reduced to a minimum width of 3.5 m at entrances, provided tight turns are not required (see Figure 2 below).

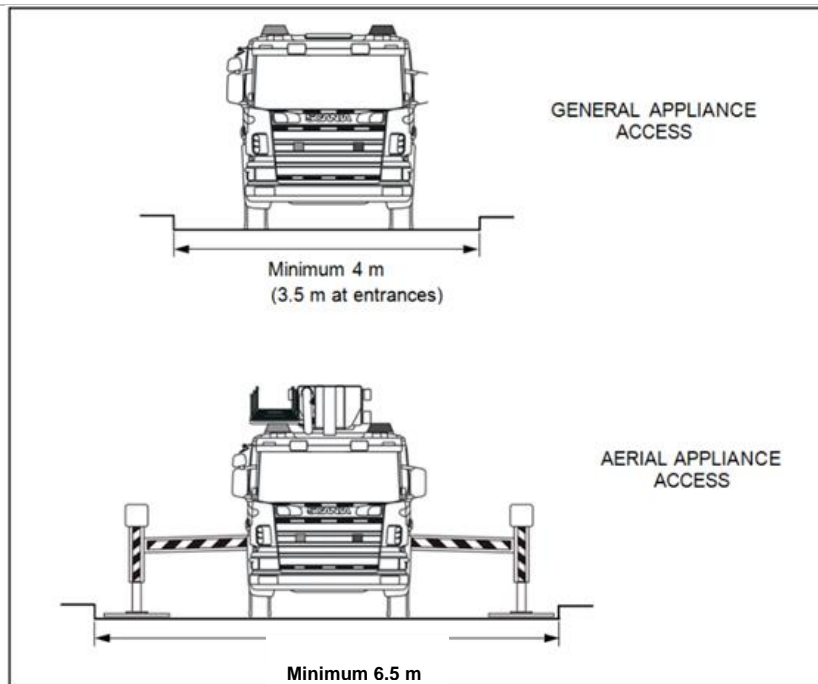

Figure 2 – Minimum carriageway widths along straight sections

Curved carriageway sections should allow for expected vehicle body swing. The minimum distance between the inner and outer arcs should be not less than 5.0 m for pumping vehicles and 7.3 m for aerial vehicles (see Figure 3).

For pumping vehicle access, the minimum inner radius should be 6.3 m and the outer radius 11.3 m. For aerial vehicle access, the minimum inner radius should be 5.2 m and the outer radius 12.5 m (see Figure 3).

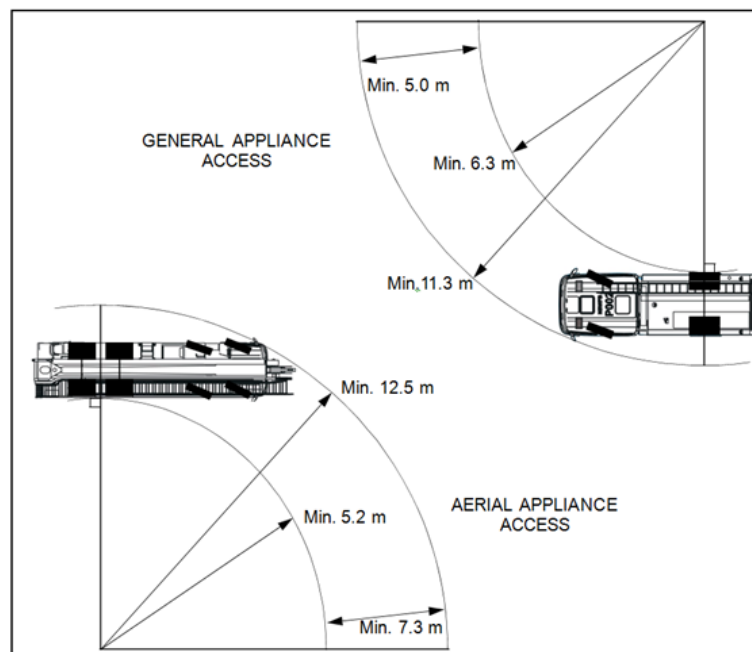

Figure 3 – Minimum carriageway widths – curved sections

The radius dimensions above are for wall-to-wall clearance from body overhang, and do not represent the vehicle's wheel tracks.



Figure 4 – Showing long rear overhang



Figure 5 – Showing long front overhang

Kerb dimensions

Kerbs built along the edges of a carriageway should be no higher than 250 mm and should be free of vertical obstructions at least 300 mm back from the kerb face to allow clearance for front and rear body overhang.

This means that if absolutely necessary, we can mount the kerb with our vehicles, although this is a last resort due to the additional hazards.

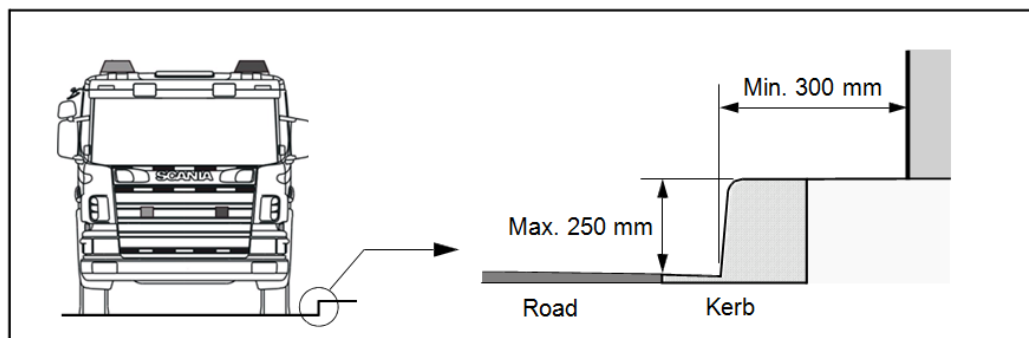

Figure 6 – Carriageway kerb clearance dimensions

Turning areas

Any carriageway with a dead end needs a turnaround area so that our vehicles don't have to do multi-point turns to turn around. This is so we can move our vehicles quickly in an emergency to protect them.

Fire and Emergency vehicles need to be able to turn a full 360° within a 25 m circle (wall-to-wall clearance) to meet Waka Kotahi NZ Transport Agency requirements. The minimum turning radius of turnaround areas should be no less than 11.3 m for pumping vehicles and 12.5 m for aerial vehicles (see Figure 3).

The Waka Kotahi NZ Transport Agency's Road and traffic guidelines for New Zealand on-road tracking curves for heavy motor vehicles (RTS 18) as indicated in Table 1, should be considered. Table 2 below summarises the tracking curves and their radii for design vehicles.

Table 2 – Turn radii and tracking curve sheet numbers for the design vehicles at various radii
 (Source: <https://www.nzta.govt.nz/assets/resources/road-traffic-standards/docs/rts-18.pdf>)

Vehicle	Radius of turn				
	10 m	12.5 m	15 m	20 m	25 m
8 m rigid truck	1	2	3	4	5
11.5 m rigid truck		6	7	8	9
Semi-trailer*		10	11	12	13
Tour coach		14	15	16	17

Table 3 – Fire and Emergency fire vehicle types in relation to the Waka Kotahi NZ Transport Agency on-road tracking curves

Fire and Emergency fire vehicle type	Waka Kotahi on-road tracking curve
Pumping appliance	8 m medium rigid truck
Aerial appliance	12.6 m rigid truck

Change of level The only acceptable means of providing access through a change of level is a ramp that meets the requirements set out below. Fire and Emergency vehicles are not designed to drive up or down steps.

Access ramps Ramps should not delay vehicle response and should provide entry and exit clearances for Fire and Emergency vehicles.

Gradients for straight ramps Fire and Emergency prefers a ramp gradient of 1:8/12.5% or less for straight ramps. The maximum straight ramp gradient our vehicles can negotiate is 1:5/20%.

Gradients for curved ramps Access ramps that follow a curved or circular profile in plan view should have a maximum gradient no greater than 1:10/10% (measured along the centre line). The vehicle chassis will twist and flex when driving up a curved ramp, so we need a lower gradient.

Change of ramp gradients Access ramps should have a smooth transition between the main ramp gradient and entry and exit gradients. A minimum 4.0 m long 1:15/6.666% transition grade is best for both ramp approach and departure (see Figure 7 below).

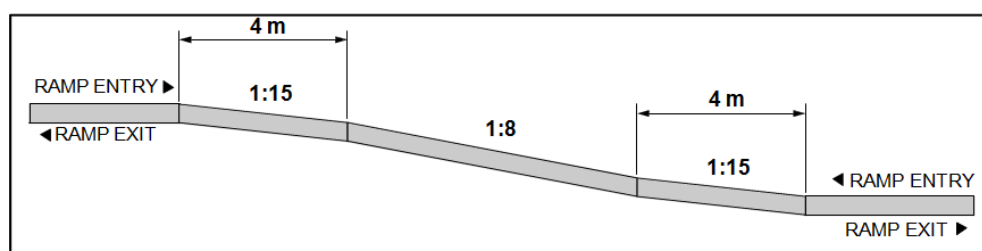

Figure 7 – Maximum access ramp gradients

Reduced gradient clearance

When a change of gradient includes a recessed threshold such as a gutter (e.g. for storm water drainage), the reduced approach and departure clearance should be allowed for in the design of the access way (see Figure 8).

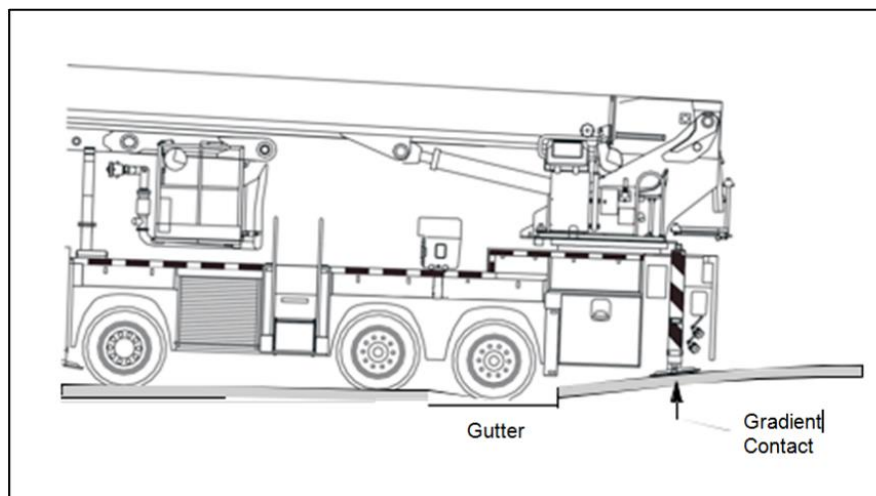

Figure 8 – Reduced gradient clearance due to gutter

When wheels go into a gutter, the body slants downwards, reducing the effective underbody clearance height at both the front and rear overhanging sections. The clearance is even smaller when the gutter is deeper and/or when the overhang is longer.

Building and structure clearance height

We need vehicle access routes to have an unobstructed clearance height of at least 4.0 m so that vehicles can pass through openings. This includes clearance from building construction, archways, gateways/doorways and overhanging structures (e.g. ducts, pipes, sprinklers, walkways, signs, structural beams, trees, hanging cables, etc.).

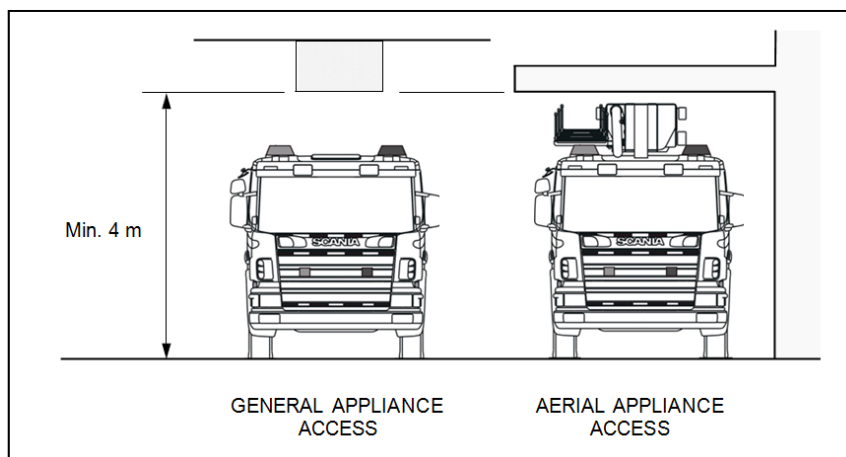

Figure 9 – Building and structure clearance heights

Note: Special considerations apply where there are both height restrictions and gradient changes. In some cases, height clearance will need to be more than 4.0 m so the vehicle can make the gradient change.

Ensuring clear access

We need clear access routes for our vehicles at all times.

Site managers should ensure that nothing blocks or partly blocks the carriageways for our vehicles. We need to be able to drive through access routes during all weather conditions. This means we need some form of hard-standing so our vehicles don't get bogged down. If a vehicle gets stuck, it creates two problems, we can't use it, and it may stop other vehicles getting through.

Perimeter security points (e.g. sliding/swinging gates, boom gates, bollards and vehicle security barriers) should not make it difficult for vehicles to gain access.



Figure 10 – Clear access available to a site

Site entrances, internal entrances and space between buildings should be at least 3.5 m wide and 4 m high.

The following common occurrences often make access difficult:

- Overhanging vegetation which restricts height clearances
- Overgrown vegetation which restricts width access and clearances
- Illegally parked vehicles in long driveways, narrow rights of way or halfway onto kerbs in small streets.

Contact us at designers.guide@fireandemergency.nz to discuss.

4.3. Vehicle weights (loads)

Static loads of vehicles

Carriageways need to be able to withstand the load of a Fire and Emergency vehicle, particularly if they are supported, elevated or reinforced by structural members (e.g. suspended floors, ramps, wharfs, aprons, etc.).

Figure 11 shows the vehicle loads exerted through the wheels that are used to determine forces acting through load-bearing structural members. Wheelbase distances between the front and back axles range from 3.7 to 5.5 m for pumping vehicles and 4.4 to 5.6 m for aerial vehicles. Designers should consider the distances between the wheels – both longitudinal and lateral – when calculating point loads for the wheels.

Note: Axle loads, such as those shown in Figure 11, are not always evenly distributed over all wheels.

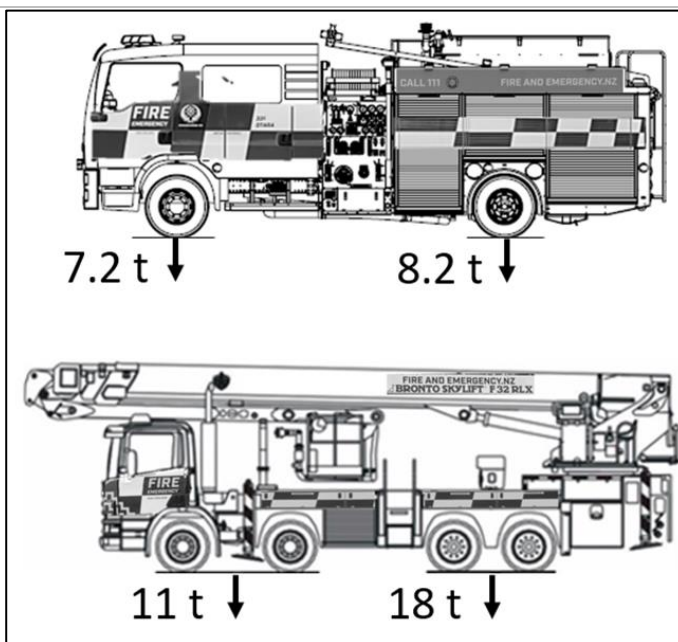

Figure 11 – Axle loads of vehicles

In general, access routes should be able to withstand a laden weight of up to 25 tonnes with an axle load of 8 tonnes or have a load-bearing capacity of no less than the public roadway serving the property, whichever is lower.

Roadway pavements designed for aerial vehicles must withstand a vehicle with multiple axles spaced at no less than 2.5 m centres and each carrying 8.2 tonnes.

The hardness of the carriageway surface should withstand static pressure of no more than 850 kPa from a vehicle's tyres.

Note: Pavements Fire and Emergency vehicles use for access should be designed according to Waka Kotahi NZ Transport Agency's HN-HO-72 traffic loading specifications, to meet the load-bearing requirements.

Dynamic loads (on aerial vehicles)

Aerial vehicles are fitted with stabilisers that prevent the vehicle from overbalancing when the aerial device is operating. Aerial vehicles will either have two stabilisers at the rear only, or more commonly, two front and two rear stabilisers (see Figure 12).

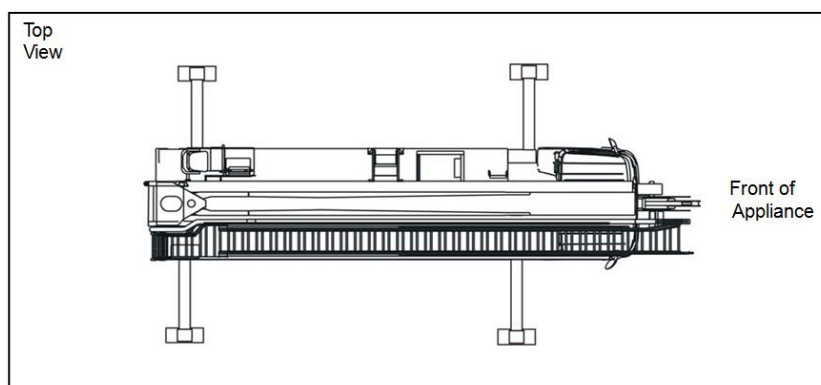

Figure 12 – General stabiliser arrangement on aerials

Extending and rotating the aerial device changes the vehicle's weight distribution and creates other forces, such as torsion moment forces. These exert dynamic forces through the stabiliser.

Note: The changing distribution of weight can cause up to 70 percent of the total vehicle weight to be borne by a single stabiliser.



Figure 13 – Highlights the space requirements for jacking stabilisers

The maximum dynamic loads and pressures exerted through a single stabiliser of the Bronto Skylift F44 RLX, with a fully loaded cage (500 kg), at maximum extension/outreach and under worst-case rotation angle, are:

- maximum stabiliser force: 200 kN
- maximum footplate pressure: 11 kg/cm² (1079 kPa)
- maximum bearing plate (block) pressure: 2.8 kg/cm² (274 kPa).

Consider the maximum exerted pressures above when calculating the minimum Allowable Bearing Pressure (ABP) for the carriageway or hard-standing area.

4.4. Site access and security features

Security features can delay site access

Many sites have security measures in place that restrict public access. These are to meet legal requirements for health and safety in the workplace and to keep the site and its staff secure.

However, enhanced security measures often delay firefighters when they investigate fire calls. Features such as security gates, high fences and bollards delay our vehicle access.

Security features can also translate to issues with physical access to buildings, including to locations where firefighters are required to interface with fire systems. Where enhanced security measures are present, this is likely to delay our investigation of the fire call.

There are solutions to overcome the issues presented by enhanced security and these include automatic unlocking or opening of security features upon a fire alarm activation. These may also have a time delay built into the system, so the site remains secure for longer, accounting for our response time. A master lock control switch could also be provided for our use in an area we can access such as a fire control centre (FCC).

Alternatively, where the building fire alarm is connected directly to Fire and Emergency, keys to the site may be provided to us.

Another option is a lockbox on site provided that information regarding its location and its access is provided to us ahead of time. On-site security staff, or contracted security staff who respond automatically in the event of a fire alarm activation, may also be able to provide access for us.

If you have any concerns about responding Fire and Emergency crews having timely access to a site, contact designers.guide@fireandemergency.nz to discuss options.

4.5. Vehicle hard-standing

Vehicle hard-standing requirements

A vehicle hard-standing is a designated area that can withstand the laden weight and associated loads of the Fire and Emergency vehicle and its crew and facilitate firefighting operations.

For our vehicles to work effectively, the hard-standing must be as close as possible to both the water supply and the structure to be protected. We encourage you to follow the guidance within this document. If you can't meet the criteria in this chapter, email designers.guide@fireandemergency.nz for help.

Under Clause C5.3 of the Building Code:

Buildings must be provided with access for fire vehicles to a hard-standing from which there is an unobstructed path to the building within 20 m of:

- (a) the firefighter access into the building, and
- (b) the inlets to automatic fire sprinkler system or fire hydrant systems, where these are installed).

This is to enable firefighter to get into the building and to move freely around our vehicles.

Under Clause C5.4 of the Building Code:

Access for fire vehicles in accordance with clause C5.3 must be provided to more than 1 side of firecells greater than 5,000m² in floor area that are not protected by automatic fire sprinkler system.

The hard-standing should:

- comply with Section 4.2 of this chapter regarding access requirements
- enclose a rectangle at least 4.0 m wide and 11 m long
- not have a gradient of more than 1:50/2%
 - Stabilisers used on aerial vehicles limit hard-standing gradients. Aerial vehicles can only use their stabilisers and operate if the ground slope is within +/- 5°
- be outside the collapse zone (see 'Collapse zone' in the Definitions section for details)
- be in the open air and have no overhead obstructions along its entire area
- be within 135 m of a pressurised water supply, or within 6 m of an open water source, due to equipment limitations (supply hose)
 - This distance should not include any sharp angles
 - This distance should be measured taking into consideration obstructions such as buildings, fences, waterways and storage or parking areas. See [Appendix B](#) for examples.

Note:

- Hose runs can be measured from this point, provided all the requirements above are satisfied.
- The above hard-standing requirements do not apply to the following classified uses (as defined in Clause A1 of the Building Code):
 - backcountry huts
 - detached dwellings
 - within household units in multi-unit dwellings
 - outbuildings
 - ancillary buildings.

Attendance point

Our policy is to respond to a single attendance point. The attendance point is generally at the building's main entrance and is often (but not always) the same as the address point. This location should include the alarm panel, building hydrant/sprinkler inlets, a suitable firefighter access point, etc.

If there is a remote place within the building which cannot be reached by hose within 75 m of the attendance point, a common solution is to provide a building hydrant system. In certain situations, this is even mandated by prescriptive guidance (for example Acceptable Solution C/AS2, paragraph 2.2.1 and associated tables)).

Note: This attendance point should not be confused with a firefighter access point or vehicular hard-standing, which may be remote from the attendance point and provided with a building hydrant outlet. It may also provide a mimic fire alarm panel or other fire safety features.

The attendance point should also include all the requirements for a hard-standing area and meet clauses C5.3 and C5.7 of the Building Code.

When identifying an attendance point, factor in the following:

- Operational procedures do not allow firefighters to drive vehicles down narrow lanes, under canopies or through flood water
- It is our policy not to park a vehicle under a canopy, or within the collapse zone in certain circumstances (see 'Collapse zone' under Definitions)
- Location of and ease of access to fire alarm panel
- Location of and ease of access to the controls for fire safety systems
- Inlets for fire sprinkler and/or building hydrant (riser) systems.

See [Appendix B](#) for examples.

Safer siting areas

We often strategically place our vehicles at building corners, particularly our aerial vehicles.

This is because the corners are generally safer if the building collapses outwards, and we can usually use our aerials across two faces of the building providing for better coverage and observation.

5. Recommendations

Fire and Emergency recommended approach

We need you to consider how you could provide access for firefighting vehicles in the course of your work. Our requirements may differ case by case, basis and you should discuss any queries you have with us.

We recommend you consider the following points:

Consider the dimensions of our vehicles

- Access gates, driveways should meet the minimum dimensions outlined.
- Driving surfaces should be designed to support the weight of our vehicles.

Consider the manoeuvrability of our vehicles

- Dead ends and turning circles should meet the requirements discussed in this chapter.
- Straight ramps designs should take in into account our vehicles' needs, particularly at ramp entry and exit points.
- Curved ramps should be carefully considered in relation to our vehicles' weights and clearances including vehicle overhangs.
- Recesses such as storm water drains should be carefully placed to consider our vehicle movements.

Consider hard-standing recommendations

- Hard-standings should be at the correct distance from building, firefighting systems/inlets and firefighting water supplies.
- Consider vehicle loading requirements for attendance and hard-standing points.
- Allow working space for firefighters in and around our vehicles. Consider:
 - doors opening
 - firefighters exiting vehicles with PPE and BA on
 - whether firefighters can access important equipment around our vehicles, such as ladders and hoses.
- Allow working space for the deployment of stabilisers on our aerial vehicles.

Consider how we will access the site in an emergency

- Consider how any site security could affect our access, particularly outside business hours.
- Keep access routes always clear, particularly from vegetation, parked cars and temporary structures, etc.
- Speed is critical – the sooner we start firefighting operations, the more likely we are to limit the consequences.

5.1. Completing the firefighting facilities checklist

Completing the checklist

When completing F5 SC Part C: 2 Access to site and 3 Access to building of the firefighting facilities checklist (FFFC), you should state what access you have given us to key facilities and the attendance point. This will allow us to understand the proposed layout and ensure that this access meets our operational needs for firefighting.

Remember that facilities are put in place for our use in emergency situations and the location of those facilities should be decided in consultation with us.

6. Related information

6.1. Designers' guide to firefighting operations

- F5 01 GD FFO Introduction
- F5-02 GD FFO Emergency vehicles access
- F5-03 GD FFO Radio communications
- F5-04 GD FFO Fire alarm panels
- F5-05 GD FFO Building hydrant systems
- F5-06 GD FFO Automatic sprinkler systems
- F5-07 GD FFO Stairs in buildings
- F5-08 GD FFO Lifts
- F5-09 GD FFO Fire Control Centres
- F5-10 GD FFO Evacuation and rescues
- F5-11 GD FFO Water supplies
- F5-12 GD FFO Construction, refurbishment and demolition sites
- F5-13 GD FFO Multi-tiered vehicle stacking buildings
- F5-14 GD FFO Firefighting shafts in taller buildings

6.2. Legislation

- [Fire and Emergency New Zealand Act 2017](#)
- [Building Act 2004](#)
- New Zealand Building Code (Building Regulations 1992 > New Zealand Building Code > [C Protection from fire](#))
- [Health and Safety at Work Act 2015](#)

6.3. Standards

- SNZ PAS 4509:2008 Firefighting water supplies code of practice
- NZS 4510:2008 Fire hydrant systems for buildings
- NZS 4510:2022 Fire hydrant systems
- NZS 4512:2021 Fire detection and alarm systems in buildings
- NZS 4541:2020 Automatic fire sprinkler systems

Note re NZS 4510:2008 and NZS 4510:2022:

[NZS 4510:2022 Fire hydrant systems](#) has superseded [NZS 4510:2008 Fire hydrant systems for buildings](#).

Fire and Emergency therefore encourages all designers and building industry practitioners to use NZS 4510:2022.

However, [C/AS2 Acceptable solutions](#) (C/AS2) still cites NZS 4510:2008, so until MBIE updates C/AS2 replacing NZS 4510:2008 with NZS 4510:2022, NZS 4510:2008 may still be used.

6.4. References

- Waka Kotahi NZ Transport Agency guidelines:
 - [Vehicle mass and dimension rules](#)
 - HN-HO-72 – [Waka Kotahi NZ Transport Agency Bridge manual \(2013\)](#)

Note: This standard covers the requirements for all pavements bearing a heavy load such as a fire appliance.

- [Road and traffic guidelines – New Zealand on-road tracking curves for heavy motor vehicles \(RTS 18\)](#)
- Acceptable Solution C/AS2 > [New Zealand Building Code Compliance C Protection from fire](#)
- [New Zealand Building Code handbook \(third edition, amendment 13\)](#)

Note: The legislation, standards and references referred to in this guide (including those listed above) are relevant at the time that this document was published. Note however that the legislation/links may have been updated since this document was published.

Appendix A – Images

Pumping appliances



Aerial appliances





Appendix B – Site layout examples

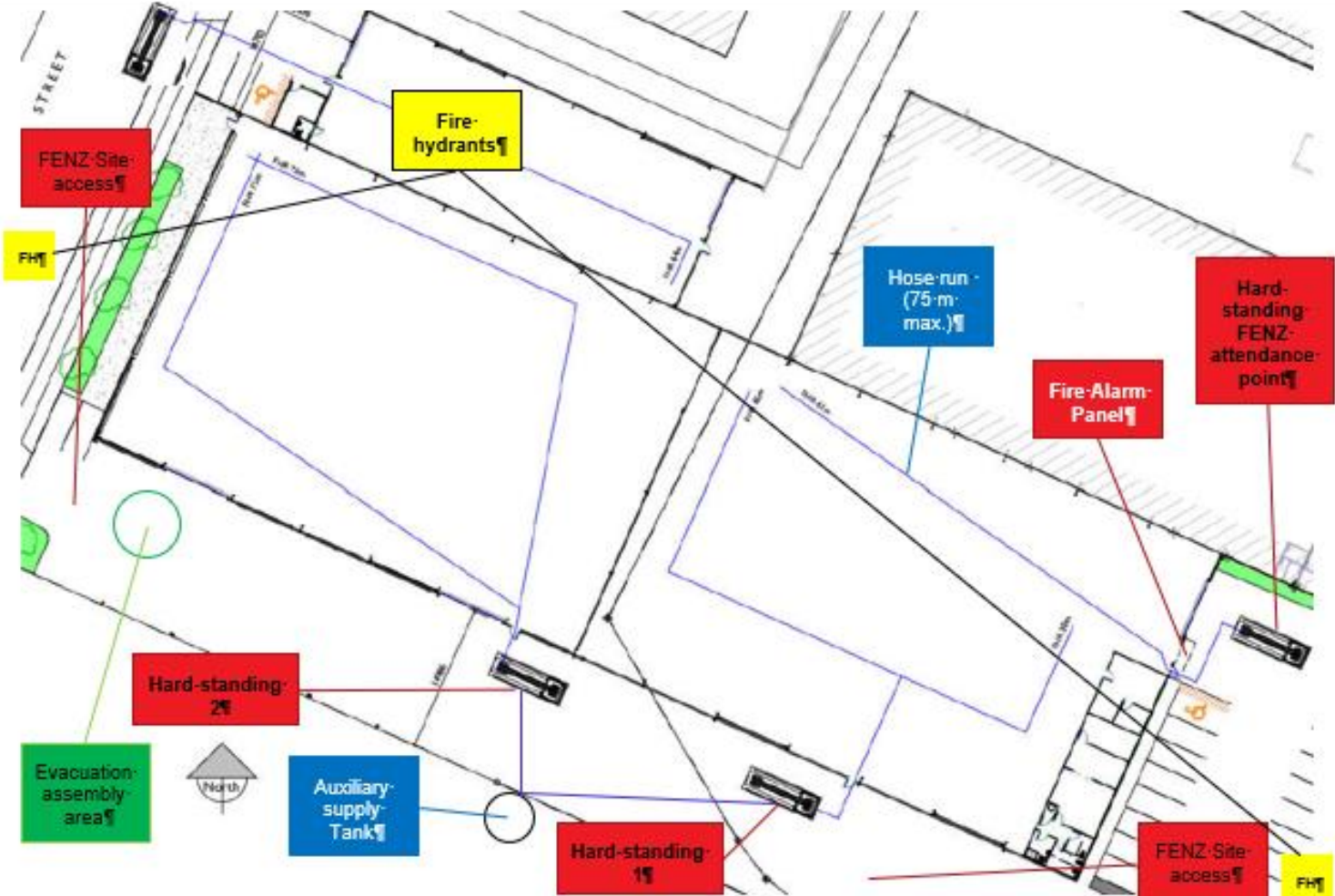

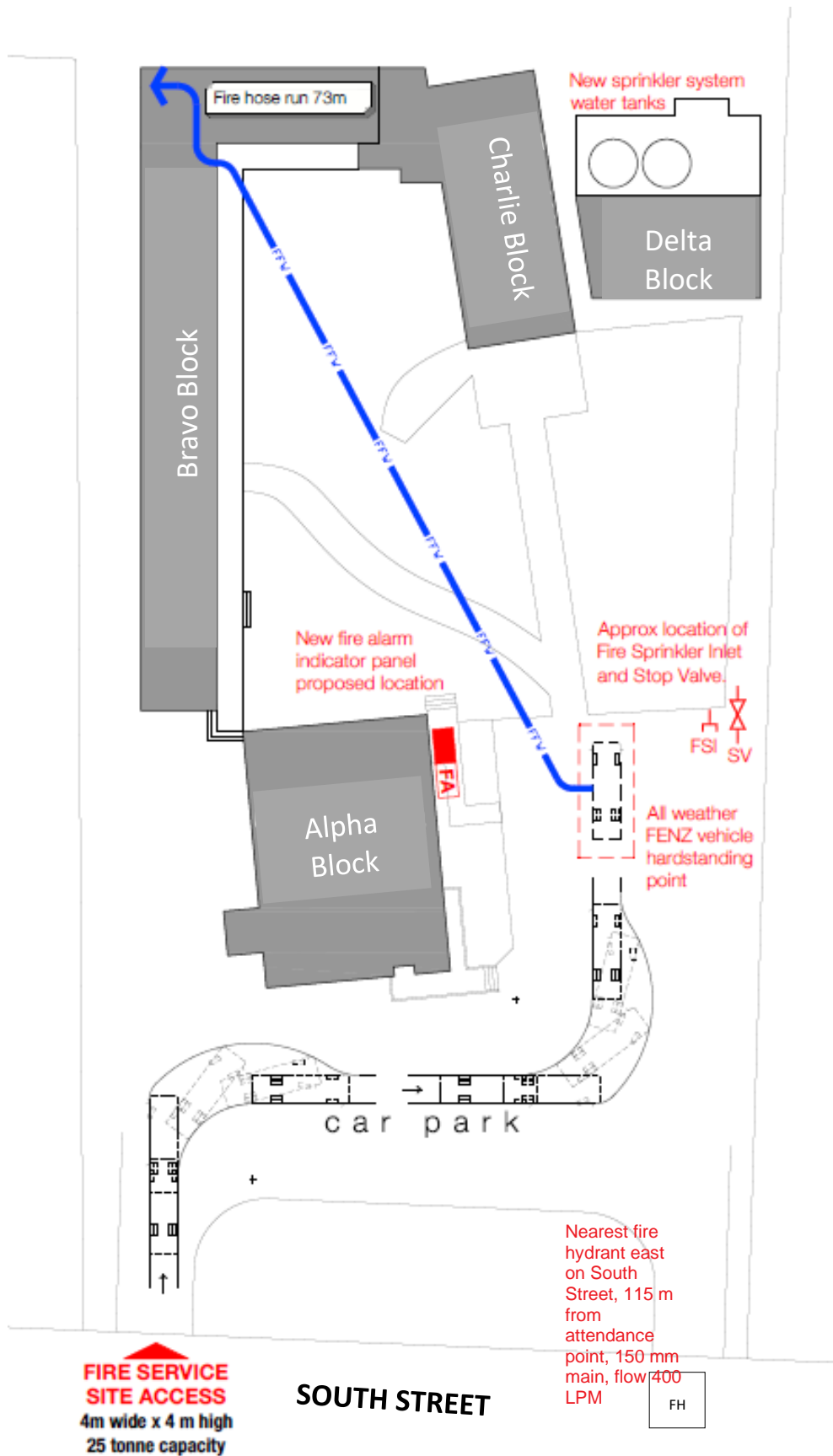

Document information

Owner	National Manager Response Capability
Last reviewed	23 July 2025
Review period	Every three years

Record of amendments

Date	Brief description of amendment
July 2025	Updated definitions: Address point, Attendance point, Hardstanding area. Review period changed to three years. Added note clarifying use of superseded hydrant standard. Expressed gradients in percentages as well as ratios. Changed label 'hose run arc' to 'hose run' in diagram in Appendix A
December 2021	Format update and SME content review
March 2018	Initial version